



HBP-1250-4 BLOWER PURGE DESICCANT AIR DRYER GENERAL ARRANGEMENT

TOLERANCES UNLESS
OTHERWISE SPECIFIED:

- FRACTIONS = ± 1/4 "
- ANGLES = ± 3°
- INCHES = ± 1/2 "
- FINISH = 250

THE SPECIFICATIONS AND DRAWINGS DISCLOSED HEREIN ARE THE SOLE PROPERTY OF ALTEC AIR, AND SHALL NOT BE COPIED OR USED AS THE BASIS FOR SALE OR MANUFACTURE WITHOUT EXPRESS WRITTEN PERMISSION.

REVISION LOG

REV.	ECO.	DESCRIPTION	DATE	APPROVED
D	1188	PRODUCTION UPDATES	10/13/2021	WS

DRAWING NO. **AT20-771** REV. **D**

DRAWN: MR DATE: 3/29/2016
CHECKED: DATE:

SCALE: N/A SHEET: 1 OF 2

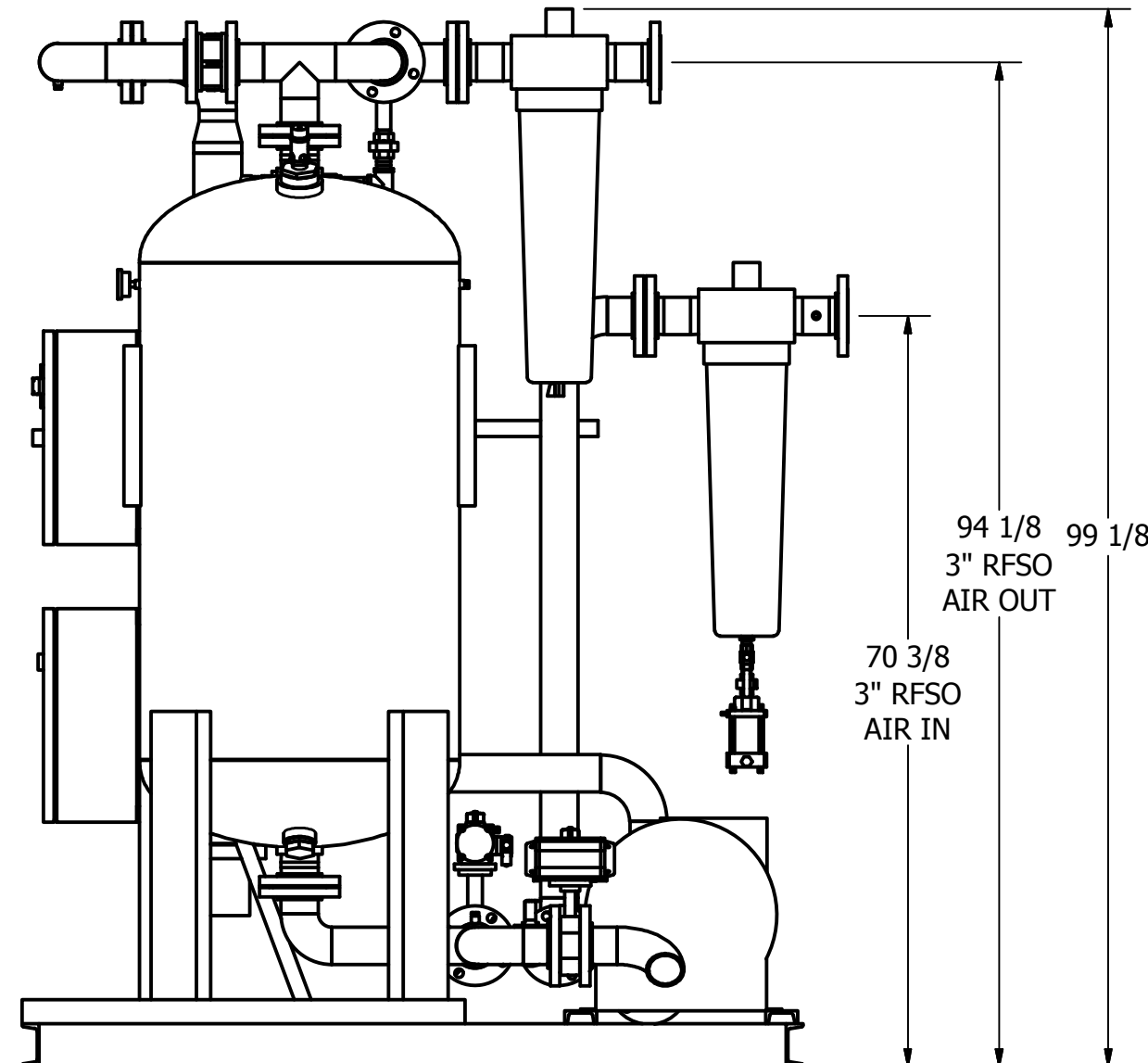
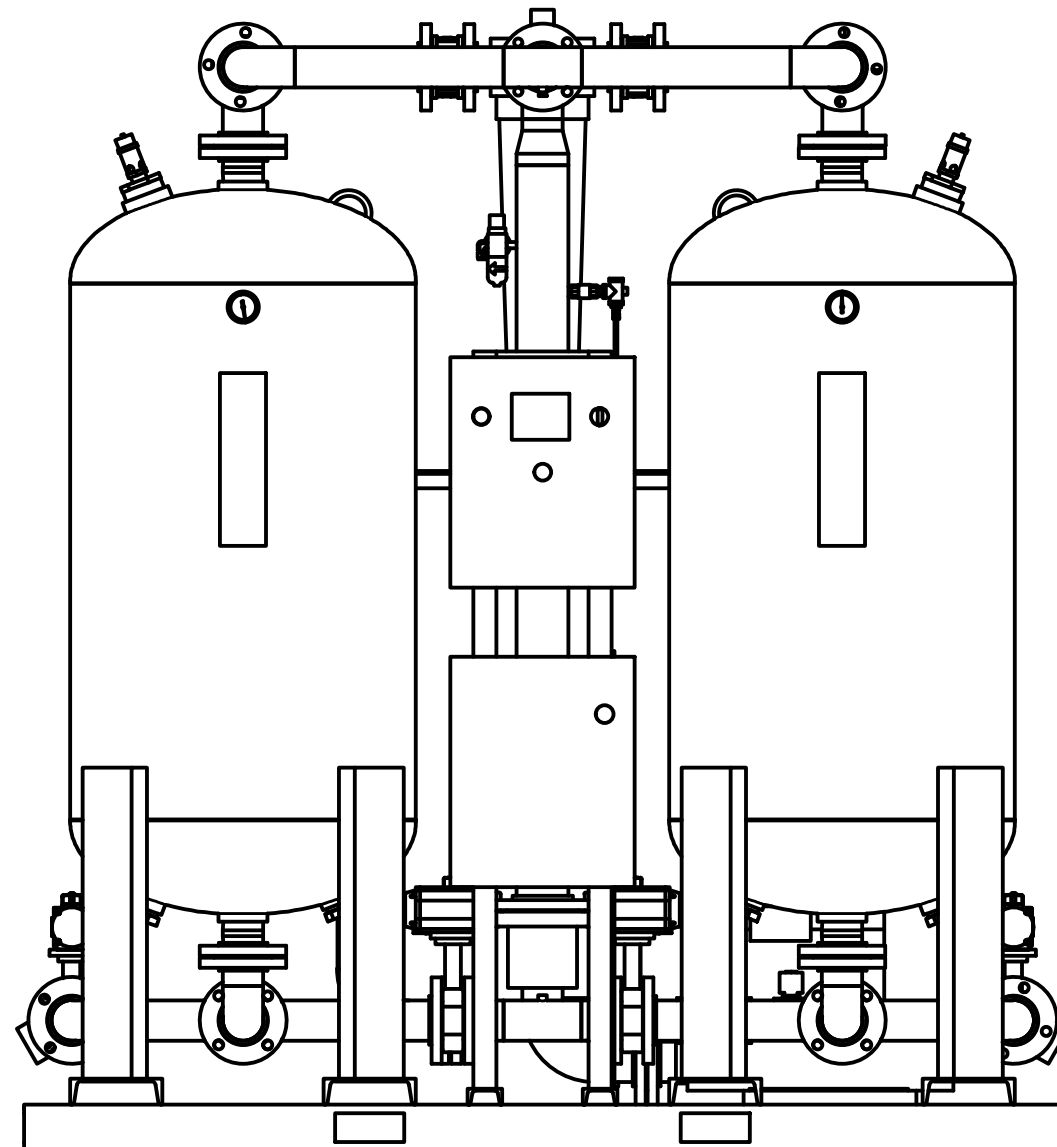
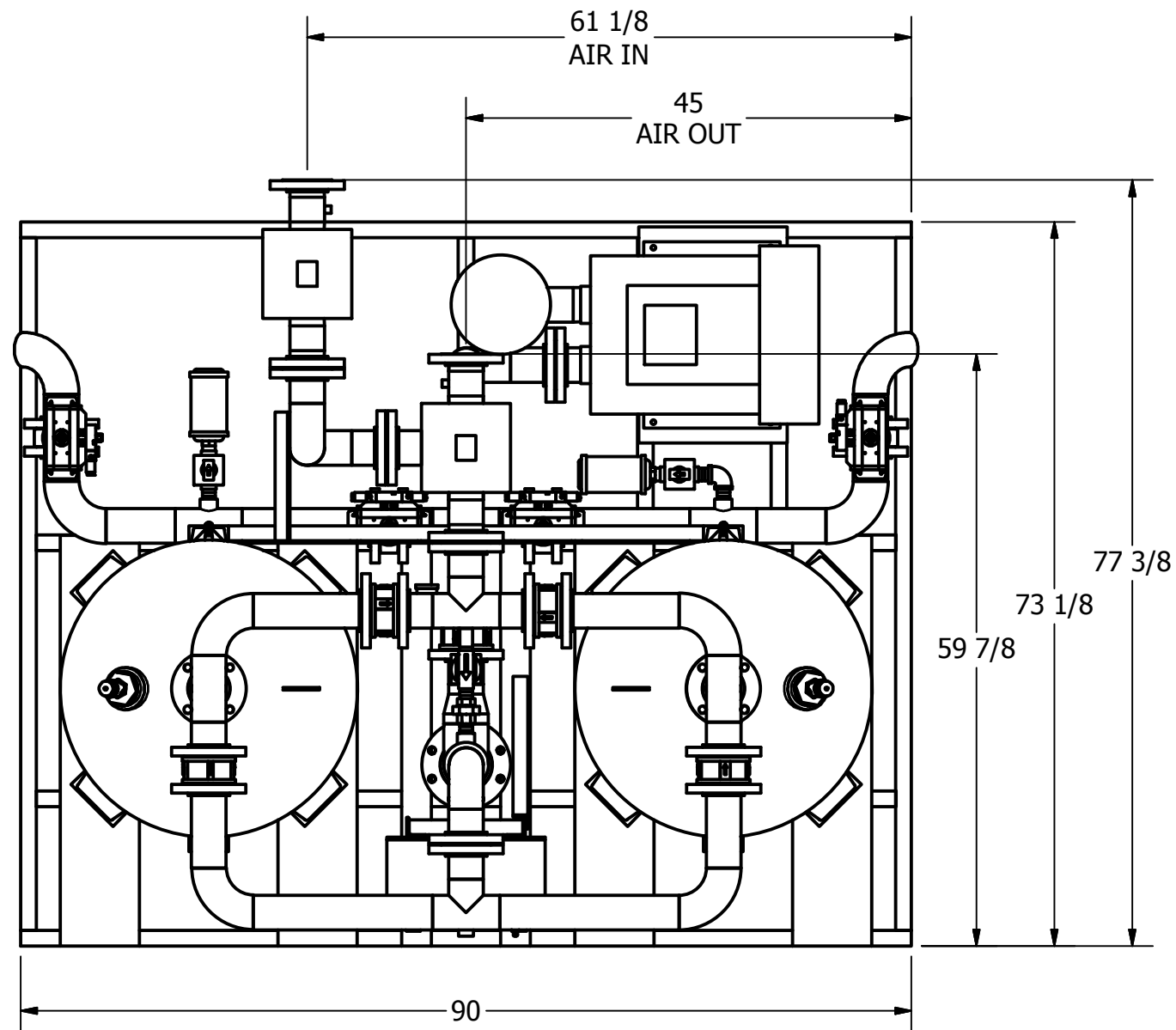
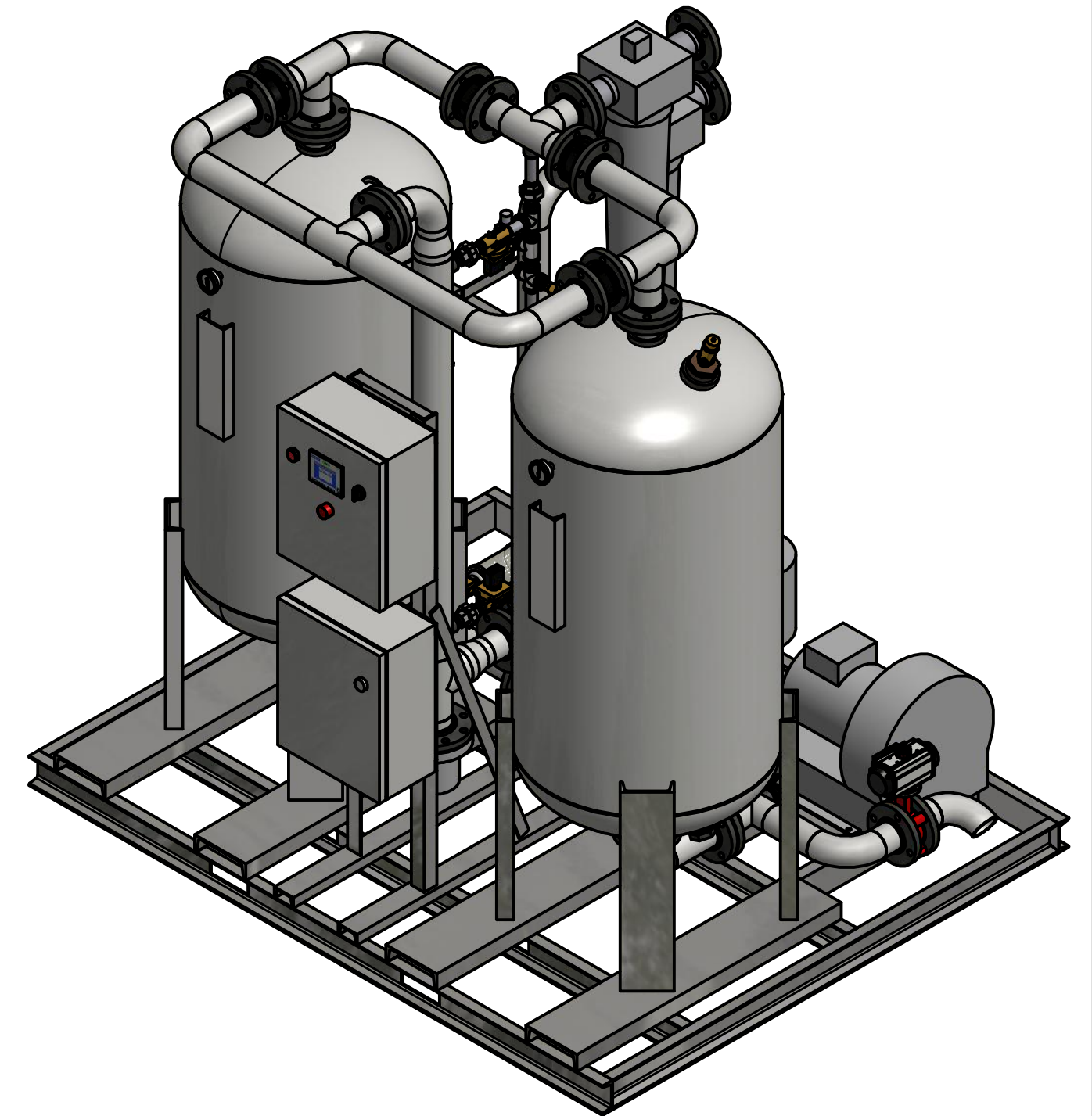

PRELIMINARY



HBP-1250-4 BLOWER PURGE DESICCANT AIR DRYER GENERAL ARRANGEMENT

TOLERANCES UNLESS
OTHERWISE SPECIFIED:

FRACTIONS = ± 1/4 "
 ANGLES = ± 3°
 INCHES = ± 1/2 "
 FINISH = 250

THE SPECIFICATIONS AND DRAWINGS DISCLOSED HEREIN ARE THE SOLE PROPERTY OF ALTEC AIR, AND SHALL NOT BE
 COPIED OR USED AS THE BASIS FOR SALE OR MANUFACTURE WITHOUT EXPRESS WRITTEN PERMISSION.

REVISION LOG

REV.	ECO.	DESCRIPTION	DATE	APPROVED
D	1188	PRODUCTION UPDATES	10/13/2021	WS

DRAWING NO. **AT20-771** REV. **D**

DRAWN: MR DATE: 3/29/2016
 CHECKED: DATE:

SCALE: N/A SHEET: 2 OF 2

PARTS LIST		
ITEM	QTY	DESCRIPTION
1	2	CHECK VALVE, PURGE
2	2	CHECK VALVE, OUTLET
3	1	SOLENOID VALVE, REPRESS
4	1	PRESSURE REGULATOR, CONTROL
5	1	PRESSURE GAUGE, CONTROL
6	1	PARTICULATE AFTER-FILTER
7	1	MOISTURE INDICATOR
8	1	DEW POINT PROBE (OPTIONAL)
9	1	COALESCING PRE-FILTER
10	1	SOLENOID VALVE, 2%
11	1	CHECK VALVE, BLOWER
12	2	RELIEF VALVE, TANK
13	2	PRESSURE GAUGE, TANK
14	1	25KW HEATER
15	2	BUTTERFLY VALVE, INLET
16	1	ZERO LOSS DRAIN
17	1	FILTER, BLOWER
18	1	5 HP BLOWER
19	2	BUTTERFLY VALVE, EXHAUST
20	2	MUFFLER, EXHAUST
21	1,850 LBS	DESSICANT

PRELIMINARY

